



Message Implementation Guideline

## **CUSCAR [From SARS]**

based on

### **CUSCAR**

Customs cargo report message

### **UN D.16B S4**

Version: 1  
Variant: 2  
Issue date: 2017/09/19  
Author: SARS EDI TEAM

1 Message Structure.....	3
2 Branching Diagram .....	5
3 Segments .....	7

---

## Structure / Table of Contents

Counter	No	Tag	St	MaxOcc	Level	Content
0000	1	<b>UNB</b>	M	1	0	Interchange header
0010	2	<b>UNH</b>	M	1	0	Message header
0020	3	<b>BGM</b>	M	1	0	Beginning of message
0030	4	<b>DTM</b>	C	9	1	Document Date
0160		<b>SG4</b>	M	9	1	Main Carriage Details
0170	5	<b>TDT</b>	M	1	1	Transport information
0210		<b>SG5</b>	C	9999	1	EQD-MEA-MEA-SEL
0220	6	<b>EQD</b>	M	1	1	Equipment details
0240	7	<b>MEA</b>	C	9	2	Gross Mass
0240	8	<b>MEA</b>	C	9	2	Verified Gross Mass
0260	9	<b>SEL</b>	C	4	2	Seal number
0340		<b>SG7</b>	C	9999	1	CNI-SG8
0350	10	<b>CNI</b>	M	1	1	Consignment information
0370		<b>SG8</b>	C	9999	2	RFF-LOC-LOC-SG14
0380	11	<b>RFF</b>	M	1	2	Reference
0410	12	<b>LOC</b>	C	99	3	Depot of Unpack
0410	13	<b>LOC</b>	C	99	3	Terminal of Discharge
0630		<b>SG14</b>	M	9999	3	GID-FTX-MEA-SGP-PCI-CST
0640	14	<b>GID</b>	M	1	3	Goods item details
0670	15	<b>FTX</b>	C	99	4	Goods Description
0680	16	<b>MEA</b>	C	99	4	Gross Mass
0700	17	<b>SGP</b>	C	9999	4	Split goods placement
0720	18	<b>PCI</b>	an..	1	4	Marks and Numbers
0730	19	<b>CST</b>	C	1	4	Customs status of goods
0890	20	<b>UNT</b>	M	1	0	Message trailer
0000	21	<b>UNZ</b>	M	1	0	Interchange trailer

Counter = Counter of segment/group within the standard  
 No = Consecutive segment number  
 MaxOcc = Maximum occurrence of the segment/group

St = Status  
 EDIFACT: M=Mandatory, C=Conditional  
 User specific: R=Required, O=Optional, D=Dependent,  
 A=Advised, N=Not used

Branching Diagram of Used Segments/Groups

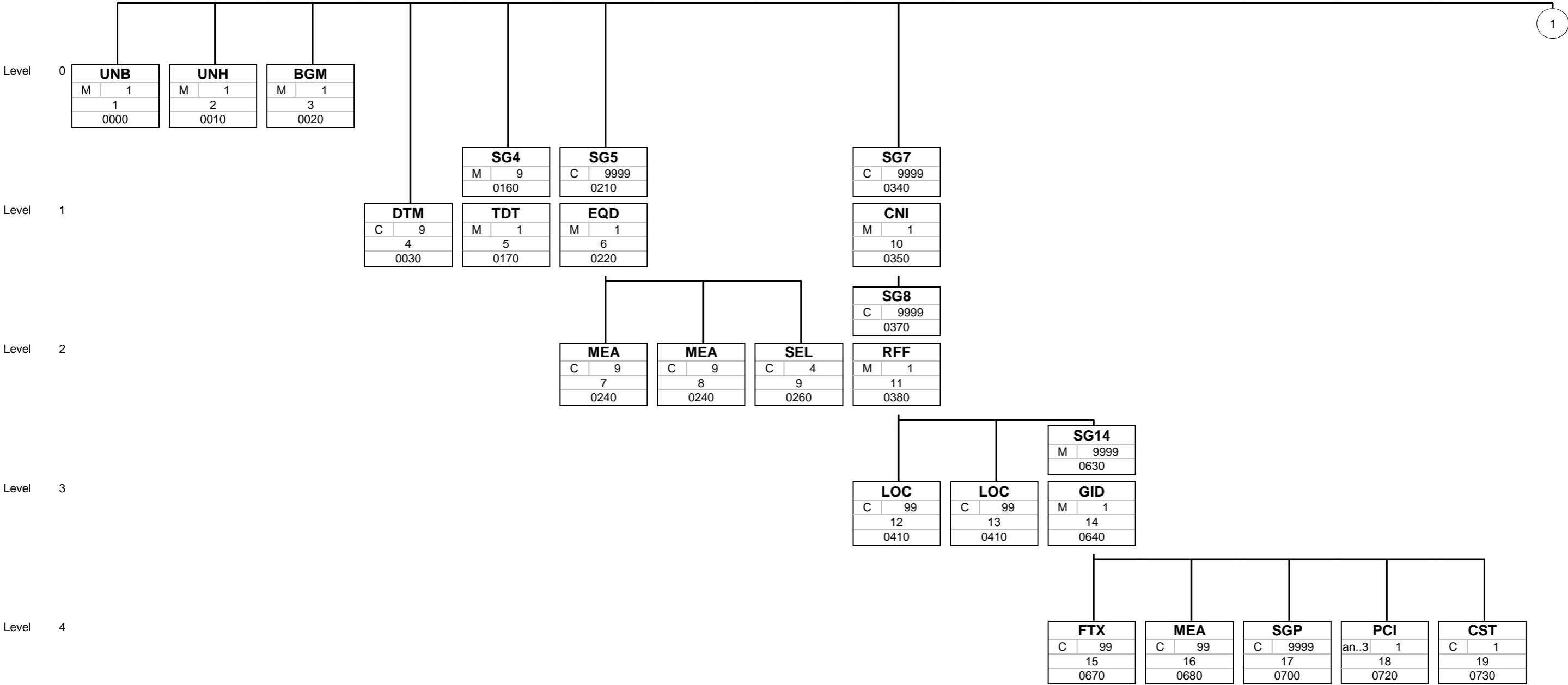

Tag
St MaxOcc
No
Counter

Tag = Segment/Group Tag  
 St = Status (M=Mandatory, C=Conditional, R=Required, O=Optional, A=Advised, D=Dependent)  
 MaxOcc = Maximum occurrence of the segment/group  
 No = Consecutive segment number  
 Counter = Counter of segment/group within the standard

# CUSCAR [From SARS]

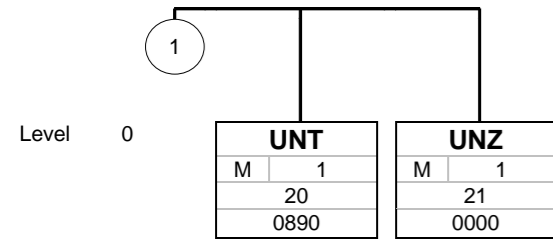

Tag
St MaxOcc
No
Counter

Tag = Segment/Group Tag  
 St = Status (M=Mandatory, C=Conditional, R=Required, O=Optional, A=Advised, D=Dependent)  
 MaxOcc = Maximum occurrence of the segment/group  
 No = Consecutive segment number  
 Counter = Counter of segment/group within the standard

# CUSCAR [From SARS]



## Segments

Counter No	Tag	St	MaxOcc	Level	Name	
0000	1	<b>UNB</b>	M	1	0	Interchange header

		Standard	Implementation		ANT	AND	Business Rules
Tag	Name	St Format	St Format	Usage / Remark			
UNB					M	M	
<b>S001</b>	<b>Syntax identifier</b>	<b>M</b>	<b>M</b>				
0001	Syntax identifier	M a4	M a4	<b>UNOB = UN/ECE level B</b>	M	M	
0002	Syntax version number	M an1	M an1	<b>4 = Version 4</b>	M	M	
0080	Service code list directory version number	C an..6	N	Not used			
0133	Character encoding, coded	C an..3	N	Not used			
0076	Syntax release number	C an2	N	Not used			
<b>S002</b>	<b>Interchange sender</b>	<b>M</b>	<b>M</b>				
0004	Interchange sender identification	M an..35	M an..35	<b>SARSCAR = Production System</b> <b>SARSCART = Test System</b>	M	M	
0007	Identification code qualifier	C an..4	N	Not used			
0008	Interchange sender internal identification	C an..35	N	Not used			
0042	Interchange sender internal sub-identification	C an..35	N	Not used			
<b>S003</b>	<b>Interchange recipient</b>	<b>M</b>	<b>M</b>				
0010	Interchange recipient identification	M an..35	M an..35	SARS assigned EDI Profile Code including dual code (if applicable)	M	M	
0007	Identification code qualifier	C an..4	N	Not used			
0014	Interchange recipient internal identification	C an..35	C an..35	Authentication code provided by SARS for EDI profile	M	M	
0046	Interchange recipient internal sub-identification	C an..35	C an..35	SARS assigned Service Provider Code (Char 1-3) <b>AS2 = AS/2</b> <b>AS3 = AS/3</b> <b>400 = X.400</b>	M	M	
<b>S004</b>	<b>Date and time of preparation</b>	<b>M</b>	<b>M</b>				
0017	Date	M n8	M n8		M	M	
0019	Time	M n4	M n4		M	M	
0020	Interchange control reference	M an..14	M an..14		M	M	
<b>S005</b>	<b>Recipient reference/ password details</b>	<b>C</b>	<b>N</b>				
0022	Recipient reference/password	M an..14	N	Not used			
0025	Recipient reference/password qualifier	C an2	N	Not used			
0026	Application reference	C an..14	C an..14	<b>CUSCAR = Customs Cargo Report</b>	O	O	
0029	Processing priority code	C a1	N	Not used			
0031	Acknowledgement request	C n1	C n1	<b>1 = Acknowledgement requested</b>	O	O	
0032	Interchange agreement identifier	C an..35	C an..35	<b>Required for X.400</b>	C	C	
0035	Test indicator	C n1	C n1	<b>Required for Test</b> <b>1 = Interchange is a test</b> Omit if Production	C	C	

**Remark:**

**Example:**

UNB+UNOB:4+12345678ABC+SARSCAR::X:X+20170619:1351+1234567890++CUSCAR++1++1'

No = Consecutive segment number  
 MaxOcc = Maximum occurrence of the segment/group  
 Counter = Counter of segment/group within the standard

St = Status  
 EDIFACT: M=Mandatory, C=Conditional  
 User specific: M=Mandatory, O=Optional, C=Conditional

# CUSCAR [From SARS]



Counter No	Tag	St	MaxOcc	Level	Name	
0010	2	<b>UNH</b>	M	1	0	Message header

Tag	Name	Standard		Implementation		Usage / Remark	ANT	AND	Business Rules
		St	Format	St	Format				
UNH							M	M	
0062	Message reference number	M	an..14	M	an..14		M	M	
<b>S009</b>	<b>Message identifier</b>	<b>M</b>		<b>M</b>					
0065	Message type	M	an..6	M	an..6	<b>CUSCAR</b> = Customs cargo report message	M	M	
0052	Message version number	M	an..3	M	an..3	<b>D</b> = Draft version/UN/EDIFACT Directory	M	M	
0054	Message release number	M	an..3	M	an..3	<b>16B</b> = Release 2016 - B	M	M	
0051	Controlling agency, coded	M	an..3	M	an..3	<b>UN</b> = UN/CEFACT	M	M	
0057	Association assigned code	C	an..6	C	an..6	<b>RCG001</b> = SARS RCG Version 1	M	M	
0110	Code list directory version number	C	an..6	N		Not used			
0113	Message type sub-function identification	C	an..6	N		Not used			
0068	Common access reference	C	an..35	N		Not used			
<b>S010</b>	<b>Status of the transfer</b>	<b>C</b>		N					
0070	Sequence of transfers	M	n..2	N		Not used			
0073	First and last transfer	C	a1	N		Not used			
<b>S016</b>	<b>Message subset identification</b>	<b>C</b>		N					
0115	Message subset identification	M	an..14	N		Not used			
0116	Message subset version number	C	an..3	N		Not used			
0118	Message subset release number	C	an..3	N		Not used			
0051	Controlling agency, coded	C	an..3	N		Not used			
<b>S017</b>	<b>Message implementation guideline identification</b>	<b>C</b>		N					
0121	Message implementation guideline identification	M	an..14	N		Not used			
0122	Message implementation guideline version number	C	an..3	N		Not used			
0124	Message implementation guideline release number	C	an..3	N		Not used			
0051	Controlling agency, coded	C	an..3	N		Not used			
<b>S018</b>	<b>Scenario identification</b>	<b>C</b>		N					
0127	Scenario identification	M	an..14	N		Not used			
0128	Scenario version number	C	an..3	N		Not used			
0130	Scenario release number	C	an..3	N		Not used			
0051	Controlling agency, coded	C	an..3	N		Not used			

**Remark:**

**Example:**

UNH+1212121212+CUSCAR:D:16B:UN:RCG001'

No = Consecutive segment number

MaxOcc = Maximum occurrence of the segment/group

Counter = Counter of segment/group within the standard

St = Status

EDIFACT: M=Mandatory, C=Conditional

User specific: M=Mandatory, O=Optional, C=Conditional

# CUSCAR [From SARS]



Counter No	Tag	St	MaxOcc	Level	Name	
0020	3	<b>BGM</b>	M	1	0	Beginning of message

		Standard	Implementation		ANT	AND	Business Rules
Tag	Name	St Format	St Format	Usage / Remark			
BGM					M	M	
<b>C002</b>	<b>Document/message name</b>	<b>C</b>	<b>M</b>				
1001	Document name code	C an..3	M an..3	<b>85</b> = Customs manifest	M	M	
1131	Code list identification code	C an..17	N	Not used			
3055	Code list responsible agency code	C an..3	N	Not used			
1000	Document name	C an..35	C an..3	<b>DOCUMENT TYPE</b> To specify document type <b>ANT</b> = Advance Notice terminal (BBB/FWB/HAB) <b>AND</b> = Advance Notice Depot (COH/ALH)	M	M	
<b>C106</b>	<b>Document/message identification</b>	<b>C</b>	<b>M</b>				
1004	Document identifier	C an..70	M an..35	<b>DOCUMENT NUMBER</b> A unique reference number assigned to the electronic document.	M	M	Each document submitted must have a unique reference and will be rejected as a duplicate if the same reference is supplied more than once. A change / deletion must have a unique reference and the referenced document reference must be supplied in document to be amended (RFF+ACW).
1056	Version identifier	C an..9	N	Not used			
1060	Revision identifier	C an..6	N	Not used			
1225	Message function code	C an..3	M an..3	<b>MESSAGE FUNCTION</b> <b>1</b> = Cancellation <b>4</b> = Change <b>9</b> = Original To specify the function of the message	M	M	A document must be accepted before it can be amended or cancelled.
4343	Response type code	C an..3	N	Not used			
1373	Document status code	C an..3	N	Not used			
3453	Language name code	C an..3	N	Not used			

**Remark:**

**Example:**

BGM+85:::COM+1234567890+9'

# CUSCAR [From SARS]



Counter No	Tag	St	MaxOcc	Level	Name	
0030	4	<b>DTM</b>	C	9	1	Document Date

		Standard	Implementation		ANT	AND	Business Rules
Tag	Name	St Format	St Format	Usage / Remark			
DTM					M	M	
<b>C507</b>	<b>Date/time/period</b>	<b>M</b>	<b>M</b>				
2005	Date or time or period function code qualifier	M an..3	M an..3	<b>137</b> = Document issue date time	M	M	
2380	Date or time or period text	C an..35	C n8	<b>DOCUMENT DATE</b> The date the manifest was produced.	M	M	
2379	Date or time or period format code	C an..3	C an..3	<b>102</b> = CCYYMMDD	M	M	

Remark:

Example:

DTM+137:20170619:102'

No = Consecutive segment number

MaxOcc = Maximum occurrence of the segment/group

Counter = Counter of segment/group within the standard

St = Status

EDIFACT: M=Mandatory, C=Conditional

User specific: M=Mandatory, O=Optional, C=Conditional



# CUSCAR [From SARS]



Counter No	Tag	St	MaxOcc	Level	Name
0160	SG4	M	9	1	Main Carriage Details
0170	5 TDT	M	1	1	Transport information

		Standard	Implementation		ANT	AND	Business Rules
Tag	Name	St Format	St Format	Usage / Remark			
TDT							
8051	Transport stage code qualifier	M an..3	M an..3	<b>20</b> = Main-carriage transport	M	M	
8028	Means of transport journey identifier	C an..17	C an..17	CONVEYANCE NUMBER	M	M	Voyage number / flight number reflected on a bill of lading or air waybill
<b>C220</b>	<b>Mode of transport</b>	<b>C</b>	<b>M</b>				
8067	Transport mode name code	C an..3	M an..2	TRANSPORT CODE 0 = Transport mode not specified 1 = Maritime transport 2 = Rail transport 3 = Road transport 4 = Air transport 5 = Mail	M	M	
8066	Transport mode name	C an..17	N	Not used			
<b>C001</b>	<b>Transport means</b>	<b>C</b>	<b>N</b>				
8179	Transport means description code	C an..8	N	Not used			
1131	Code list identification code	C an..17	N	Not used			
3055	Code list responsible agency code	C an..3	N	Not used			
8178	Transport means description	C an..17	N	Not used			
<b>C040</b>	<b>Carrier</b>	<b>C</b>	<b>an..17</b>				
3127	Carrier identifier	C an..17	M an..17	CARRIER CODE <a href="https://tools.sars.gov.za/ACM_code_Tables/Carrier*.csv">https://tools.sars.gov.za/ACM_code_Tables/Carrier*.csv</a>	M	M	The BIC, SCAC, IATA or SARS-assigned code of a shipping line, airline, rail carrier or road carrier carrying on business by transporting goods for reward or transporting goods in the course of conducting its business.  For rail use "TFR"
1131	Code list identification code	C an..17	C an..17	<b>172</b> = Carrier code	M	M	
3055	Code list responsible agency code	C an..3	C an..3	<b>20</b> = BIC (Bureau International des Containeurs) <b>166</b> = US, National Motor Freight Classification Association <b>3</b> = IATA (International Air Transport Association) <b>ZZZ</b> = South African Revenue Service	X	X	
3126	Carrier name	C an..35	N	Not used			
8101	Transit direction indicator code	C an..3	N	Not used			
<b>C401</b>	<b>Excess transportation information</b>	<b>C</b>	<b>N</b>				
8457	Excess transportation reason code	M an..3	N	Not used			
8459	Excess transportation responsibility code	M an..3	N	Not used			
7130	Customer shipment authorisation identifier	C an..17	N	Not used			
<b>C222</b>	<b>Transport identification</b>	<b>C</b>	<b>C</b>				
8213	Transport means identification name identifier	C an..35	C an..35	TRANSPORT ID <a href="https://tools.sars.gov.za/ACM_code_Tables/Transport*.csv">https://tools.sars.gov.za/ACM_code_Tables/Transport*.csv</a>	O	M	Radio Call Sign/Registration Number of aircraft
1131	Code list identification code	C an..17	C an..17	<b>103</b> = Call sign directory <b>146</b> = Means of transport identification	X	X	
3055	Code list responsible agency code	C an..3	N	Not used			
8212	Transport means identification name	C an..70	N	Not used			
8453	Transport means nationality code	C an..3	N	Not used			

No = Consecutive segment number  
 MaxOcc = Maximum occurrence of the segment/group  
 Counter = Counter of segment/group within the standard  
 St = Status  
 EDIFACT: M=Mandatory, C=Conditional  
 User specific: M=Mandatory, O=Optional, C=Conditional

# CUSCAR [From SARS]



		Standard	Implementation					
Tag	Name	St Format	St Format	Usage / Remark	ANT	AND	Business Rules	
8281	Transport means ownership indicator code	C an..3	N	Not used				
<b>C003</b>	<b>Power type</b>	<b>C</b>	<b>N</b>					
7041	Power type code	C an..3	N	Not used				
1131	Code list identification code	C an..17	N	Not used				
3055	Code list responsible agency code	C an..3	N	Not used				
7040	Power type description	C an..17	N	Not used				

**Remark:**

**Example:**  
TDT+20+987544+1++ABCD::20+++ABCD123'

No = Consecutive segment number  
 MaxOcc = Maximum occurrence of the segment/group  
 Counter = Counter of segment/group within the standard  
 St = Status  
 EDIFACT: M=Mandatory, C=Conditional  
 User specific: M=Mandatory, O=Optional, C=Conditional

# CUSCAR [From SARS]



Counter No	Tag	St	MaxOcc	Level	Name
0210	SG5	C	9999	1	EQD-MEA-SEL
0220	6 EQD	M	1	1	Equipment details

Standard		Implementation		Usage / Remark	ANT	AND	Business Rules
Tag	Name	St Format	St Format				
EQD						M	
8053	Equipment type code qualifier	M an..3	M an..3	EQUIPMENT QUALIFIER CN = Container RR = Rail car		M	
<b>C237</b>	<b>Equipment identification</b>	<b>C</b>	<b>C</b>				
8260	Equipment identifier	C an..17	C an..17	CONTAINER NUMBER/WAGON NUMBER		M	The container number consists of 11 digits of which the first 4 digits represent the alphabetic code and the next 7 digits represent the numeric number of the container. For rail, if containerised, insert the container number. If not containerised insert the wagon number.
1131	Code list identification code	C an..17	N	Not used			
3055	Code list responsible agency code	C an..3	N	Not used			
3207	Country identifier	C an..3	N	Not used			
<b>C224</b>	<b>Equipment size and type</b>	<b>C</b>	<b>N</b>				
8155	Equipment size and type description code	C an..10	N	Not used			
1131	Code list identification code	C an..17	N	Not used			
3055	Code list responsible agency code	C an..3	N	Not used			
8154	Equipment size and type description	C an..35	N	Not used			
8077	Equipment supplier code	C an..3	N	Not used			
8249	Equipment status code	C an..3	N	Not used			
8169	Full or empty indicator code	C an..3	N	Not used			
4233	Marking instructions code	C an..3	N	Not used			

**Remark:**  
This segment will occur once for each container specified.  
**NOTE:** Only required for Containerised Cargo, not required if not containerised.

**Example:**  
EQD+CN+CN01234567890'

No = Consecutive segment number  
MaxOcc = Maximum occurrence of the segment/group  
Counter = Counter of segment/group within the standard

St = Status  
EDIFACT: M=Mandatory, C=Conditional  
User specific: M=Mandatory, O=Optional, C=Conditional

# CUSCAR [From SARS]

Counter No	Tag	St	MaxOcc	Level	Name
0210	<b>SG5</b>	C	9999	1	EQD-MEA-SEL
0240	7 <b>MEA</b>	C	9	2	Gross Mass

		Standard	Implementation		ANT	AND	Business Rules
Tag	Name	St Format	St Format	Usage / Remark			
MEA							
6311	Measurement purpose code qualifier	M an..3	M an..3	<b>AAE</b> = Measurement		M	
<b>C502</b>	<b>Measurement details</b>	<b>C</b>	<b>C</b>				
6313	Measured attribute code	C an..3	C an..3	<b>AAM</b> = Transport means gross weight		M	
6321	Measurement significance code	C an..3	N	Not used			
6155	Non-discrete measurement name code	C an..17	N	Not used			
6154	Non-discrete measurement name	C an..70	N	Not used			
<b>C174</b>	<b>Value/range</b>	<b>C</b>	<b>C</b>				
6411	Measurement unit code	C an..8	C an..3	<b>UNIT OF MEASURE</b> <b>KGM</b> = kilogram		M	
6314	Measure	C an..18	C an..18	<b>GROSS MASS</b>		M	
6162	Range minimum quantity	C n..18	N	Not used			
6152	Range maximum quantity	C n..18	N	Not used			
6432	Significant digits quantity	C n..2	N	Not used			
7383	Surface or layer code	C an..3	N	Not used			

**Remark:**

**Example:**

MEA+AAE+AAM+KGM: 2356'

# CUSCAR [From SARS]

Counter No	Tag	St	MaxOcc	Level	Name
0210	<b>SG5</b>	C	9999	1	EQD-MEA-SEL
0240	8 <b>MEA</b>	C	9	2	Verified Gross Mass

		Standard	Implementation		ANT	AND	Business Rules
Tag	Name	St Format	St Format	Usage / Remark			
MEA							
6311	Measurement purpose code qualifier	M an..3	M an..3	<b>AAE</b> = Measurement		M	
<b>C502</b>	<b>Measurement details</b>	<b>C</b>	<b>C</b>				
6313	Measured attribute code	C an..3	C an..3	<b>VGM</b> = Transport equipment verified gross mass (weight)		M	
6321	Measurement significance code	C an..3	N	Not used			
6155	Non-discrete measurement name code	C an..17	N	Not used			
6154	Non-discrete measurement name	C an..70	N	Not used			
<b>C174</b>	<b>Value/range</b>	<b>C</b>	<b>C</b>				
6411	Measurement unit code	C an..8	C an..3	<b>VERIFIED GROSS MASS UNIT</b> <b>KGM</b> = kilogram		M	
6314	Measure	C an..18	C an..18	<b>VERIFIED GROSS MASS MASS</b>		M	As prescribed in terms of the Safety of Life at Sea Convention (SOLAS)
6162	Range minimum quantity	C n..18	N	Not used			
6152	Range maximum quantity	C n..18	N	Not used			
6432	Significant digits quantity	C n..2	N	Not used			
7383	Surface or layer code	C an..3	N	Not used			

**Remark:**

**Example:**

MEA+AAE+VGM+KGM: 2356'

# CUSCAR [From SARS]



Counter No	Tag	St	MaxOcc	Level	Name
0210	<b>SG5</b>	C	9999	1	EQD-MEA-SEL
0260	9 <b>SEL</b>	C	4	2	Seal number

		Standard	Implementation		ANT	AND	Business Rules
Tag	Name	St Format	St Format	Usage / Remark			
SEL						M	
9308	Transport unit seal identifier	C an..35	C an..35	SEAL NUMBER		M	Should no Seal Number be available, "NO SEAL NO" must be specified within this field. This segment may occur a maximum of four times.
<b>C215</b>	<b>Seal issuer</b>	<b>C</b>	N				
9303	Sealing party name code	C an..3	N	Not used			
1131	Code list identification code	C an..17	N	Not used			
3055	Code list responsible agency code	C an..3	N	Not used			
9302	Sealing party name	C an..35	N	Not used			
4517	Seal condition code	C an..3	N	Not used			
<b>C208</b>	<b>Identity number range</b>	<b>C</b>	N				
7402	Object identifier	M an..35	N	Not used			
7402	Object identifier	C an..35	N	Not used			
4525	Seal type code	C an..3	N	Not used			

**Remark:**

**Example:**

SEL+1321321313113131321321'

# CUSCAR [From SARS]



Counter No	Tag	St	MaxOcc	Level	Name
0340	SG7	C	9999	1	CNI-SG8
0350 10	CNI	M	1	1	Consignment information

		Standard	Implementation		ANT	AND	Business Rules
Tag	Name	St Format	St Format	Usage / Remark			
CNI							
1490	Consolidation item number	C n..5	N	Not used			
<b>C503</b>	<b>Document/message details</b>	<b>C</b>	<b>C</b>				
1004	Document identifier	C an..70	C an..70	MASTER TRANSPORT DOCUMENT NUMBER	M	M	Master / Ocean Bill of Lading, Air Waybill, Rail Consignment Note, Road Freight Manifest
1373	Document status code	C an..3	N	Not used			
1366	Document source description	C an..70	N	Not used			
3453	Language name code	C an..3	N	Not used			
1056	Version identifier	C an..9	C an..9	MASTER TRANSPORT DOCUMENT DATE Date to be supplied in format CCYYMMDD.	M	M	
1060	Revision identifier	C an..6	N	Not used			
1312	Consignment load sequence identifier	C n..4	N	Not used			

**Remark:**

**Example:**

CNI++112233445566778899:::20170601'

# CUSCAR [From SARS]



Counter No	Tag	St	MaxOcc	Level	Name
0370	<b>SG8</b>	C	9999	2	RFF-LOC-SG14
0380 11	<b>RFF</b>	M	1	2	Reference

		Standard	Implementation		ANT	AND	Business Rules
Tag	Name	St Format	St Format	Usage / Remark			
RFF							
<b>C506</b>	<b>Reference</b>	<b>M</b>	<b>M</b>				
1153	Reference code qualifier	M an..3	M an..3	<b>BM = Bill of lading number</b>			
1154	Reference identifier	C an..70	C an..70	<b>TRANSPORT DOCUMENT NUMBER</b>	M	M	<p>In the case of FCL and LCL cargo information submitted by the Carrier, this field will contain the MasterBill Of Lading number.</p> <p>In the case of FCL Groupage cargo information submitted by a Broker, this field will contain the House Bill Of Lading Number.</p> <p>For Air, in the case of a Master Air Waybill in respect of straight cargo, the Master Air Waybill Number will also be reflected here.</p> <p>For air, in the case of consolidated cargo, the House Air Waybill number will be reflected here.</p> <p>In respect of a sub-consolidations the House Air Waybill Number / Bill of Lading Number issued by the co-loading agent to the consignee must be reflected here.</p> <p>For Rail, supply the Rail Consignment Note Number.</p> <p>For Road, this is the Waybill/Invoice Number issued by theCarrier for an individual consignment.</p>
1156	Document line identifier	C an..6	N	Not used			
1056	Version identifier	C an..9	N	Not used			
1060	Revision identifier	C an..6	N	Not used			

**Remark:**

**Example:**

RFF+BM:1112223333444555666777888999000'



# CUSCAR [From SARS]



Counter No	Tag	St	MaxOcc	Level	Name
0370	SG8	C	9999	2	RFF-LOC-SG14
0410 12	LOC	C	99	3	Depot of Unpack

		Standard	Implementation		ANT	AND	Business Rules
Tag	Name	St Format	St Format	Usage / Remark			
LOC						M	
3227	Location function code qualifier	M an..3	M an..3	104 = Place of deconsolidation		M	
<b>C517</b>	<b>Location identification</b>	<b>C</b>	<b>C</b>				
3225	Location identifier	C an..35	C an..35	DEPOT OF UNPACK <i>For INBOUND manifest, the following rules apply:</i> <i>If BBB and FWB, HAB - Terminal of Discharge is Mandatory, Depot of unpack is Optional</i> <i>If ALH, COH, - Depot of Unpack is Mandatory, Terminal of Discharge is Mandatory</i> SARS Facility Codes		M	
1131	Code list identification code	C an..17	N	Not used			
3055	Code list responsible agency code	C an..3	N	Not used			
3224	Location name	C an..256	N	Not used			
<b>C519</b>	<b>Related location one identification</b>	<b>C</b>	<b>N</b>				
3223	First related location identifier	C an..35	N	Not used			
1131	Code list identification code	C an..17	N	Not used			
3055	Code list responsible agency code	C an..3	N	Not used			
3222	First related location name	C an..70	N	Not used			
<b>C553</b>	<b>Related location two identification</b>	<b>C</b>	<b>N</b>				
3233	Second related location identifier	C an..35	N	Not used			
1131	Code list identification code	C an..17	N	Not used			
3055	Code list responsible agency code	C an..3	N	Not used			
3232	Second related location name	C an..70	N	Not used			
5479	Relation code	C an..3	N	Not used			

**Remark:**

**Example:**

LOC+104+17'

# CUSCAR [From SARS]



Counter No	Tag	St	MaxOcc	Level	Name
0370	SG8	C	9999	2	RFF-LOC-SG14
0410 13	LOC	C	99	3	Terminal of Discharge

		Standard	Implementation		ANT	AND	Business Rules
Tag	Name	St Format	St Format	Usage / Remark			
LOC					M		
3227	Location function code qualifier	M an..3	M an..3	65 = Final port or place of discharge	M		
<b>C517</b>	<b>Location identification</b>	<b>C</b>	<b>C</b>				
3225	Location identifier	C an..35	C an..17	TERMINAL OF DISCHARGE <i>For INBOUND manifest, the following rules apply:</i> <i>If BBB and FWB, HAB - Terminal of Discharge is Mandatory, Depot of unpack is Optional</i> <i>If ALH, COH, - Depot of Unpack is Mandatory, Terminal of Discharge is Mandatory</i> SARS Facility Codes	M		
1131	Code list identification code	C an..17	N	Not used			
3055	Code list responsible agency code	C an..3	N	Not used			
3224	Location name	C an..256	N	Not used			
<b>C519</b>	<b>Related location one identification</b>	<b>C</b>	<b>N</b>				
3223	First related location identifier	C an..35	N	Not used			
1131	Code list identification code	C an..17	N	Not used			
3055	Code list responsible agency code	C an..3	N	Not used			
3222	First related location name	C an..70	N	Not used			
<b>C553</b>	<b>Related location two identification</b>	<b>C</b>	<b>N</b>				
3233	Second related location identifier	C an..35	N	Not used			
1131	Code list identification code	C an..17	N	Not used			
3055	Code list responsible agency code	C an..3	N	Not used			
3232	Second related location name	C an..70	N	Not used			
5479	Relation code	C an..3	N	Not used			

Remark:

Example:

LOC+65+01'

# CUSCAR [From SARS]



Counter No	Tag	St	MaxOcc	Level	Name
0630	<b>SG14</b>	M	9999	3	GID-FTX-MEA-SGP-PCI-CST
0640 14	<b>GID</b>	M	1	3	Goods item details

Standard		Implementation		ANT	AND	Business Rules	
Tag	Name	St Format	St Format	Usage / Remark			
GID							
1496	Goods item number	C an..6	C n..5	GOODS LINE NUMBER	M	M	Sequential goods line number in respect of the goods for this consignment, starting at 1 and incrementing by 1 for each line. If cargo is vehicles, each vehicle must be reflected as a separate repeat of Group 10 with Description in FTX segment , VIN number in PCI segment and VN as type of package in GID segment. If more than one type of hazardous cargo, repeat Group 10 for each type of hazardous cargo.
<b>C213</b>	<b>Number and type of packages</b>	<b>C</b>	<b>C</b>				
7224	Package quantity	C n..8	C n..8	NUMBER OF PACKAGES <i>For Bulk/Break Bulk manifests where the cargo type is Break Bulk, number and type of packages must be declared.</i>	M	M	
7065	Package type description code	C an..17	C an..17	TYPE OF PACKAGES <i>For Bulk/Break Bulk manifests where the cargo type is Break Bulk, number and type of packages must be declared.</i> <a href="#">UN Recommendation 21</a>	M	M	Use VN (Vehicle) for vehicles as cargo
1131	Code list identification code	C an..17	N	Not used			
3055	Code list responsible agency code	C an..3	N	Not used			
7064	Type of packages	C an..35	N	Not used			
7233	Packaging related description code	C an..3	N	Not used			
<b>C213</b>	<b>Number and type of packages</b>	<b>C</b>	<b>N</b>				
7224	Package quantity	C n..8	N	Not used			
7065	Package type description code	C an..17	N	Not used			
1131	Code list identification code	C an..17	N	Not used			
3055	Code list responsible agency code	C an..3	N	Not used			
7064	Type of packages	C an..35	N	Not used			
7233	Packaging related description code	C an..3	N	Not used			
<b>C213</b>	<b>Number and type of packages</b>	<b>C</b>	<b>N</b>				
7224	Package quantity	C n..8	N	Not used			
7065	Package type description code	C an..17	N	Not used			
1131	Code list identification code	C an..17	N	Not used			
3055	Code list responsible agency code	C an..3	N	Not used			
7064	Type of packages	C an..35	N	Not used			
7233	Packaging related description code	C an..3	N	Not used			
<b>C213</b>	<b>Number and type of packages</b>	<b>C</b>	<b>N</b>				
7224	Package quantity	C n..8	N	Not used			
7065	Package type description code	C an..17	N	Not used			
1131	Code list identification code	C an..17	N	Not used			
3055	Code list responsible agency code	C an..3	N	Not used			
7064	Type of packages	C an..35	N	Not used			
7233	Packaging related description code	C an..3	N	Not used			

No = Consecutive segment number  
MaxOcc = Maximum occurrence of the segment/group  
Counter = Counter of segment/group within the standard

St = Status  
EDIFACT: M=Mandatory, C=Conditional  
User specific: M=Mandatory, O=Optional, C=Conditional

# CUSCAR [From SARS]



		Standard	Implementation					
Tag	Name	St Format	St Format	Usage / Remark	ANT	AND	Business Rules	
<b>C213</b>	<b>Number and type of packages</b>	<b>C</b>	N					
7224	Package quantity	C n..8	N	Not used				
7065	Package type description code	C an..17	N	Not used				
1131	Code list identification code	C an..17	N	Not used				
3055	Code list responsible agency code	C an..3	N	Not used				
7064	Type of packages	C an..35	N	Not used				
7233	Packaging related description code	C an..3	N	Not used				

**Remark:**

**Example:**

GID+1+9:BX'

No = Consecutive segment number

MaxOcc = Maximum occurrence of the segment/group

Counter = Counter of segment/group within the standard

St = Status

EDIFACT: M=Mandatory, C=Conditional

User specific: M=Mandatory, O=Optional, C=Conditional

# CUSCAR [From SARS]



Counter No	Tag	St	MaxOcc	Level	Name
0630	SG14	M	9999	3	GID-FTX-MEA-SGP-PCI-CST
0670 15	FTX	C	99	4	Goods Description

Standard		Implementation			ANT	AND	Business Rules
Tag	Name	St Format	St Format	Usage / Remark			
FTX					M	M	
4451	Text subject code qualifier	M an..3	M an..3	AAA = Goods item description	M	M	
4453	Free text function code	C an..3	N	Not used			
<b>C107</b>	<b>Text reference</b>	<b>C</b>	<b>N</b>				
4441	Free text description code	M an..17	N	Not used			
1131	Code list identification code	C an..17	N	Not used			
3055	Code list responsible agency code	C an..3	N	Not used			
<b>C108</b>	<b>Text literal</b>	<b>C</b>	<b>C</b>				
4440	Free text	M an..512	M an..35	DESCRIPTION OF GOODS - 1 <i>At least one of DESCRIPTION OF GOODS or COMMODITY CODE NUMBER must be provided</i>	M	M	
4440	Free text	C an..512	C an..35	DESCRIPTION OF GOODS - 2	O	O	
4440	Free text	C an..512	C an..35	DESCRIPTION OF GOODS - 3	O	O	
4440	Free text	C an..512	C an..35	DESCRIPTION OF GOODS - 4	O	O	
4440	Free text	C an..512	C an..35	DESCRIPTION OF GOODS - 5	O	O	
3453	Language name code	C an..3	N	Not used			
4447	Free text format code	C an..3	N	Not used			

**Remark:**

**Example:**

FTX+AAA++Widgets:etc:etc:etc:etc'

# CUSCAR [From SARS]

Counter No	Tag	St	MaxOcc	Level	Name
0630	<b>SG14</b>	M	9999	3	GID-FTX-MEA-SGP-PCI-CST
0680 16	<b>MEA</b>	C	99	4	Gross Mass

		Standard	Implementation		ANT	AND	Business Rules
Tag	Name	St Format	St Format	Usage / Remark			
MEA					M	M	
6311	Measurement purpose code qualifier	M an..3	M an..3	<b>AAE = Measurement</b>	M	M	
<b>C502</b>	<b>Measurement details</b>	<b>C</b>	<b>C</b>				
6313	Measured attribute code	C an..3	C an..3	<b>AAB = Goods item gross weight</b>	M	M	
6321	Measurement significance code	C an..3	N	Not used			
6155	Non-discrete measurement name code	C an..17	N	Not used			
6154	Non-discrete measurement name	C an..70	N	Not used			
<b>C174</b>	<b>Value/range</b>	<b>C</b>	<b>C</b>				
6411	Measurement unit code	C an..8	C an..3	<b>UNIT OF MEASURE (MASS / WEIGHT)</b> <b>KGM = kilogram</b>	M	M	
6314	Measure	C an..18	C an..18	<b>GROSS MASS / WEIGHT</b>	M	M	Gross mass of the item described.
6162	Range minimum quantity	C n..18	N	Not used			
6152	Range maximum quantity	C n..18	N	Not used			
6432	Significant digits quantity	C n..2	N	Not used			
7383	Surface or layer code	C an..3	N	Not used			

**Remark:**

**Example:**

MEA+AAE+AAB+KGM:1000'

# CUSCAR [From SARS]



Counter No	Tag	St	MaxOcc	Level	Name
0630	<b>SG14</b>	M	9999	3	GID-FTX-MEA-SGP-PCI-CST
0700 17	<b>SGP</b>	C	9999	4	Split goods placement

		Standard	Implementation		ANT	AND	Business Rules
Tag	Name	St Format	St Format	Usage / Remark			
SGP							
<b>C237</b>	<b>Equipment identification</b>	<b>M</b>	<b>M</b>			<b>M</b>	
8260	Equipment identifier	C an..17	C an..17	CONTAINER NUMBER/WAGON NUMBER Must be specified on EQD segment as well		<b>M</b>	Specify in which container(s) the goods are NOTE: SGP only required for Containerised Cargo, not required if not containerised.
1131	Code list identification code	C an..17	N	Not used			
3055	Code list responsible agency code	C an..3	N	Not used			
3207	Country identifier	C an..3	N	Not used			
7224	Package quantity	C n..8	N	Not used			

**Remark:**

**Example:**

SGP+CNU1234567890'

No = Consecutive segment number

MaxOcc = Maximum occurrence of the segment/group

Counter = Counter of segment/group within the standard

St = Status

EDIFACT: M=Mandatory, C=Conditional

User specific: M=Mandatory, O=Optional, C=Conditional

# CUSCAR [From SARS]



Counter No	Tag	St	MaxOcc	Level	Name
0630	SG14	M	9999	3	GID-FTX-MEA-SGP-PCI-CST
0720 18	PCI	an..35	1	4	Marks and Numbers

		Standard	Implementation		ANT	AND	Business Rules
Tag	Name	St Format	St Format	Usage / Remark			
PCI					M	M	
4233	Marking instructions code	C an..3	C an..3	24 = Shipper assigned	M	M	
<b>C210</b>	<b>Marks &amp; labels</b>	<b>C</b>	<b>C</b>				
7102	Shipping marks description	M an..35	M an..35	MARKS AND NUMBERS - 1 <i>Where packaging type is VN (Used for vehicles) the Marks and numbers must contain the Vehicle VIN number in the format "VIN=" followed by the VIN number.</i>	M	M	Mandatory for Break Bulk, Sea and Air. Optional for Road When cargo is motor vehicle must be "VIN=" followed by VIN number
7102	Shipping marks description	C an..35	C an..35	MARKS AND NUMBERS - 2	O	O	
7102	Shipping marks description	C an..35	C an..35	MARKS AND NUMBERS - 3	O	O	
7102	Shipping marks description	C an..35	C an..35	MARKS AND NUMBERS - 4	O	O	
7102	Shipping marks description	C an..35	C an..35	MARKS AND NUMBERS - 5	O	O	
7102	Shipping marks description	C an..35	C an..35	MARKS AND NUMBERS - 6	O	O	
7102	Shipping marks description	C an..35	C an..35	MARKS AND NUMBERS - 7	O	O	
7102	Shipping marks description	C an..35	C an..35	MARKS AND NUMBERS - 8	O	O	
7102	Shipping marks description	C an..35	C an..35	MARKS AND NUMBERS - 9	O	O	
7102	Shipping marks description	C an..35	C an..35	MARKS AND NUMBERS - 10	O	O	
8169	Full or empty indicator code	C an..3	N	Not used			
<b>C827</b>	<b>Type of marking</b>	<b>C</b>	<b>N</b>				
7511	Marking type code	M an..3	N	Not used			
1131	Code list identification code	C an..17	N	Not used			
3055	Code list responsible agency code	C an..3	N	Not used			

**Remark:**

**Example:**  
 PCI+24+Marks and numbers 1:Marks and numbers 2:Marks and numbers 3:Marks and numbers 4:Marks and numbers 5:Marks and numbers 6:Marks and numbers 7:Marks and numbers 8:Marks and numbers 9:Marks and numbers 10'



# CUSCAR [From SARS]



Counter No	Tag	St	MaxOcc	Level	Name
0630	<b>SG14</b>	M	9999	3	GID-FTX-MEA-SGP-PCI-CST
0730 19	<b>CST</b>	C	1	4	Customs status of goods

		Standard	Implementation		ANT	AND	Business Rules
Tag	Name	St Format	St Format	Usage / Remark			
CST					O	O	
1496	Goods item number	C an..6	N	Not used			
<b>C246</b>	<b>Customs identity codes</b>	<b>C</b>	<b>C</b>				
7361	Customs goods identifier	M an..18	M an..18	COMMODITY CODE NUMBER <i>At least one of DESCRIPTION OF GOODS or COMMODITY CODE NUMBER must be provided</i>	O	O	Six H.S. Digit Tariff Code.
1131	Code list identification code	C an..17	N	Not used			
3055	Code list responsible agency code	C an..3	N	Not used			
<b>C246</b>	<b>Customs identity codes</b>	<b>C</b>	<b>N</b>				
7361	Customs goods identifier	M an..18	N	Not used			
1131	Code list identification code	C an..17	N	Not used			
3055	Code list responsible agency code	C an..3	N	Not used			
<b>C246</b>	<b>Customs identity codes</b>	<b>C</b>	<b>N</b>				
7361	Customs goods identifier	M an..18	N	Not used			
1131	Code list identification code	C an..17	N	Not used			
3055	Code list responsible agency code	C an..3	N	Not used			
<b>C246</b>	<b>Customs identity codes</b>	<b>C</b>	<b>N</b>				
7361	Customs goods identifier	M an..18	N	Not used			
1131	Code list identification code	C an..17	N	Not used			
3055	Code list responsible agency code	C an..3	N	Not used			

Remark:  
Example:  
CST++630411000'

# CUSCAR [From SARS]



Counter	No	Tag	St	MaxOcc	Level	Name
0890	20	<b>UNT</b>	M	1	0	Message trailer

		Standard	Implementation		ANT	AND	Business Rules
Tag	Name	St Format	St Format	Usage / Remark			
UNT							
0074	Number of segments in a message	M n..10	M n..10	Number of segments from UNH to UNT (including both)			
0062	Message reference number	M an..14	M an..14	Must match Message Reference Number in UNH			

**Remark:**

**Example:**

UNT+68+1212121212'

No = Consecutive segment number  
 MaxOcc = Maximum occurrence of the segment/group  
 Counter = Counter of segment/group within the standard  
 St = Status  
 EDIFACT: M=Mandatory, C=Conditional  
 User specific: M=Mandatory, O=Optional, C=Conditional

# CUSCAR [From SARS]



Counter	No	Tag	St	MaxOcc	Level	Name
0000	21	<b>UNZ</b>	M	1	0	Interchange trailer

		Standard	Implementation		ANT	AND	Business Rules
Tag	Name	St Format	St Format	Usage / Remark			
UNZ							
0036	Interchange control count	M n..6	M n..6	Number of messages in interchange			
0020	Interchange control reference	M an..14	M an..14	Must match Interchange control reference in UNB			

**Remark:**

**Example:**  
UNZ+1+1234567890'

No = Consecutive segment number  
 MaxOcc = Maximum occurrence of the segment/group  
 Counter = Counter of segment/group within the standard  
 St = Status  
 EDIFACT: M=Mandatory, C=Conditional  
 User specific: M=Mandatory, O=Optional, C=Conditional